

Can supersolidity be suppressed in stiffened solid ^4He ?

Eunseong Kim



Center for Supersolid & Quantum matter Research

KAIST, Republic of Korea

Outline

- ▶ Shear Modulus Anomaly
- ▶ Simultaneous Measurements :
NCRI & Shear Modulus
 - What is common?
 - What is different?
- ▶ Summary

Shear modulus increase in Solid Helium

J. Day, and J. Beamish, Nature **450**, 853 (2007).

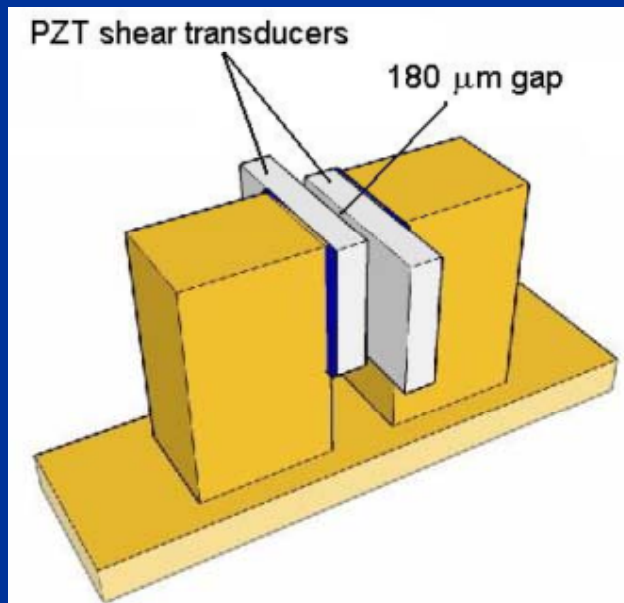

$$\mu = \frac{d_{15}^2 D}{2\pi A} \frac{I}{fV}$$

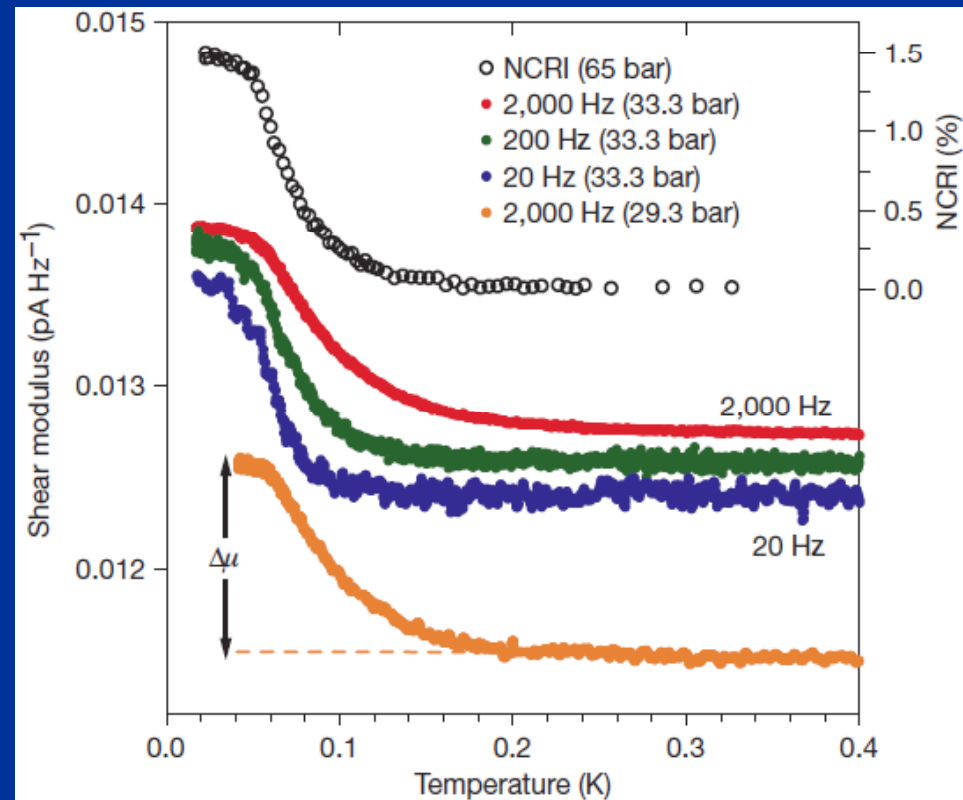

Shear modulus increase by dislocation pinning to ^3He impurities without invoking superfluidity

A. Granato, K. Lucke, *J. of Appl. Phys.* 27, 583 (1956).

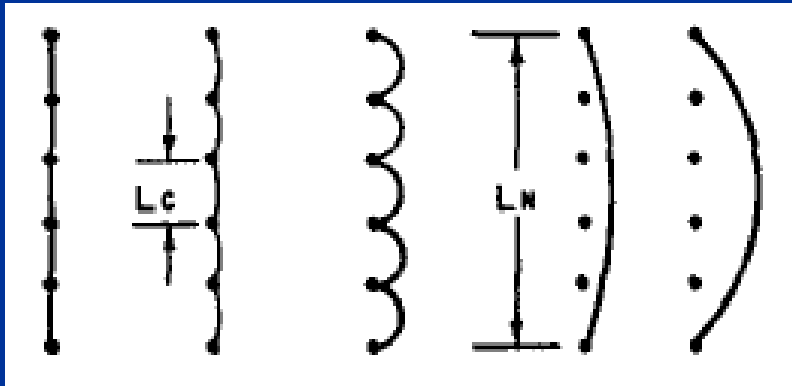

With most dislocations strongly pinned by impurities at low temperatures, the shear modulus is close to that of a perfect crystal.

- The detachment of impurities by thermal evaporation reduces μ by a fraction proportional to ΛL^2 at high temperatures.

$$\frac{\Delta\mu}{\mu} = C\Lambda L^2$$

Striking similarities

- Drive dependence

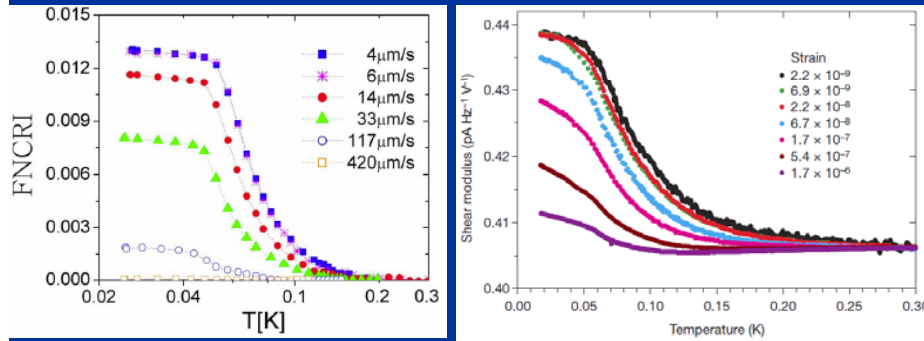

- ³He concentration dependence

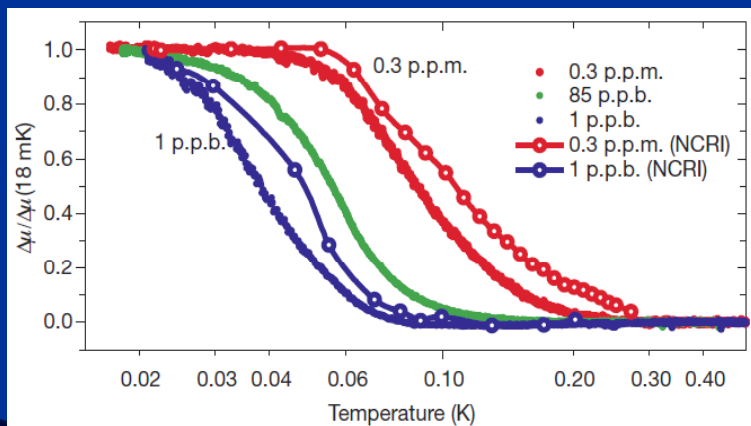

- Frequency dependence

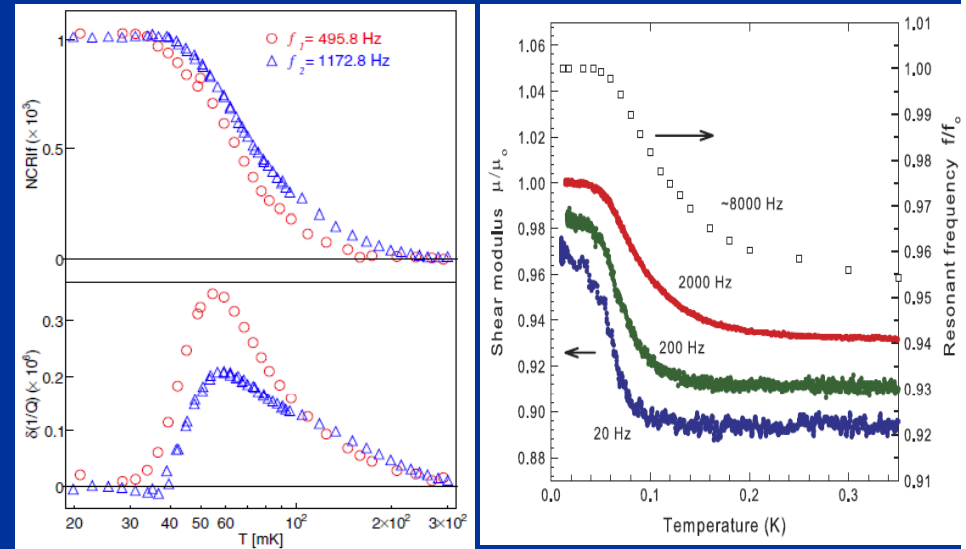

Y. Aoki, J. C. Graves, and H. Kojima, PRL 99, (2007)

Two phenomena should be closely related !

Reduction in the resonant period can be understood by stiffening of solid helium ?

Shear modulus stiffening possibly mimic the NCRI.

$$\frac{df}{f} \approx \left(\frac{d \ln f}{d \ln \mu} \right) \frac{\delta \mu}{\mu} \quad \left(\frac{d \ln f}{d \ln \mu} \right) \Rightarrow 5 \sim 10 \text{ ppm}$$

However, the estimated value is too small.
Elastic stiffening alone cannot explain the NCRI.

Clark et al., PRB (2008)

NCRI occurs only in a stiffened Bose solid.

Effect in Fermi solid ^3He ?

J. T. West, O. Syshchenko, J. Beamish, M. H. W. Chan, *Nat Phys* 5, 598 (2009)

Shear modulus is crystal structure dependent.

NCRI is quantum statistics dependent.

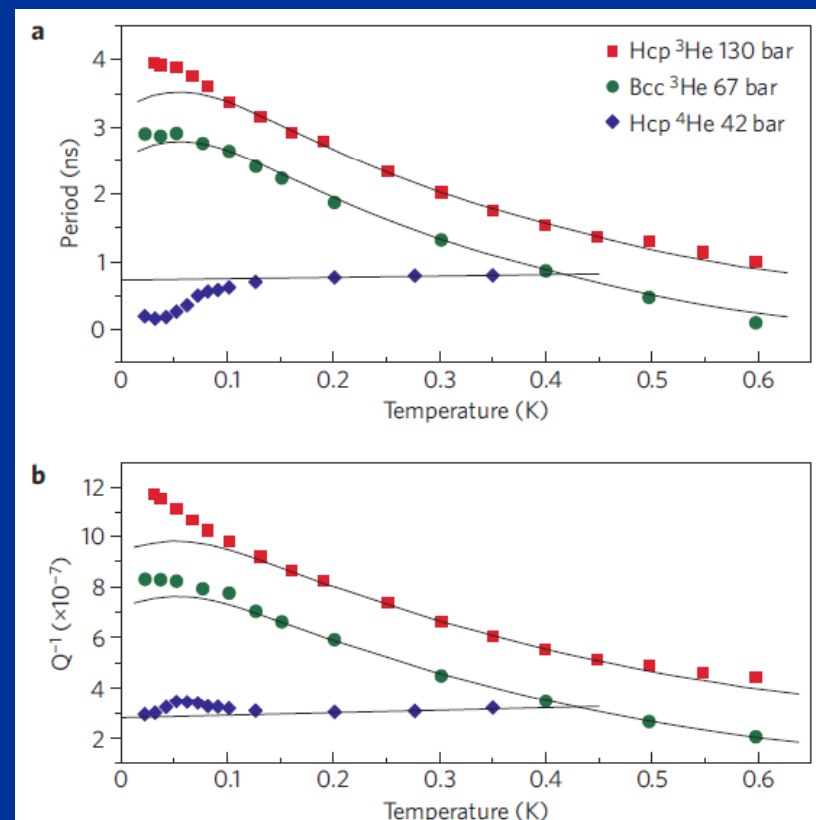
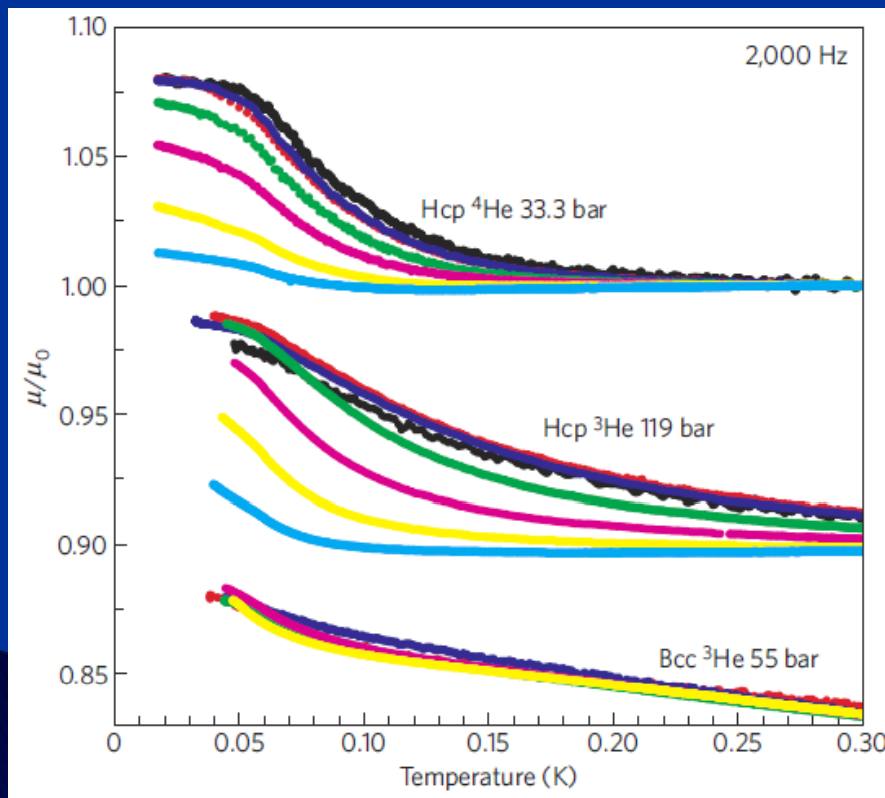

How NCRI and shear modulus are related?

Striking similarities found, but NCRI shows quantum statistics dependence

- ▶ The appearance of NCRI seems to require the stiffening of solid helium.
- ▶ It is better to measure both phenomena simultaneously

Experiments

- ▶ Torsional Oscillator
 - Resonant Freq: 911 Hz
 - Q factor: 6×10^5
 - Annular channel
 - Diameter: 16 mm
 - width: 400 μm

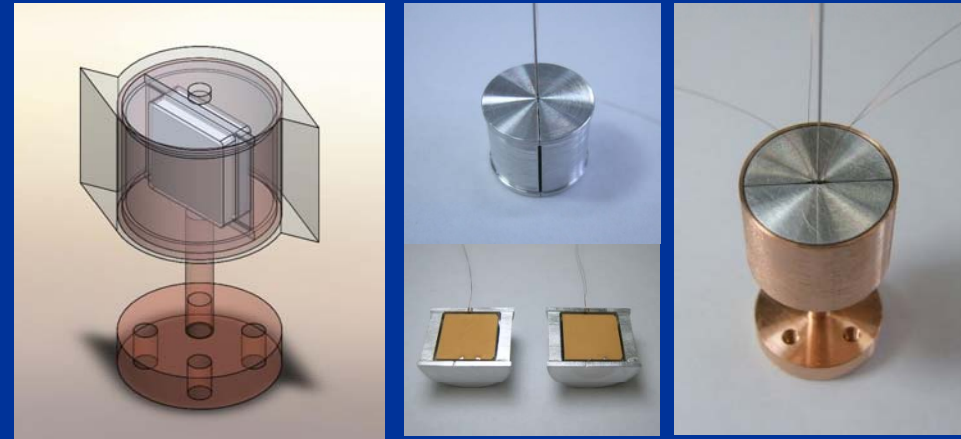

- ▶ PZT shear transducer
 - Area : 1 cm x 1 cm
 - gap : 400 μm
 - d_{15} at low temperature 1.5×10^{-10} m/V
 - frequency range: 10 Hz ~ 40 kHz

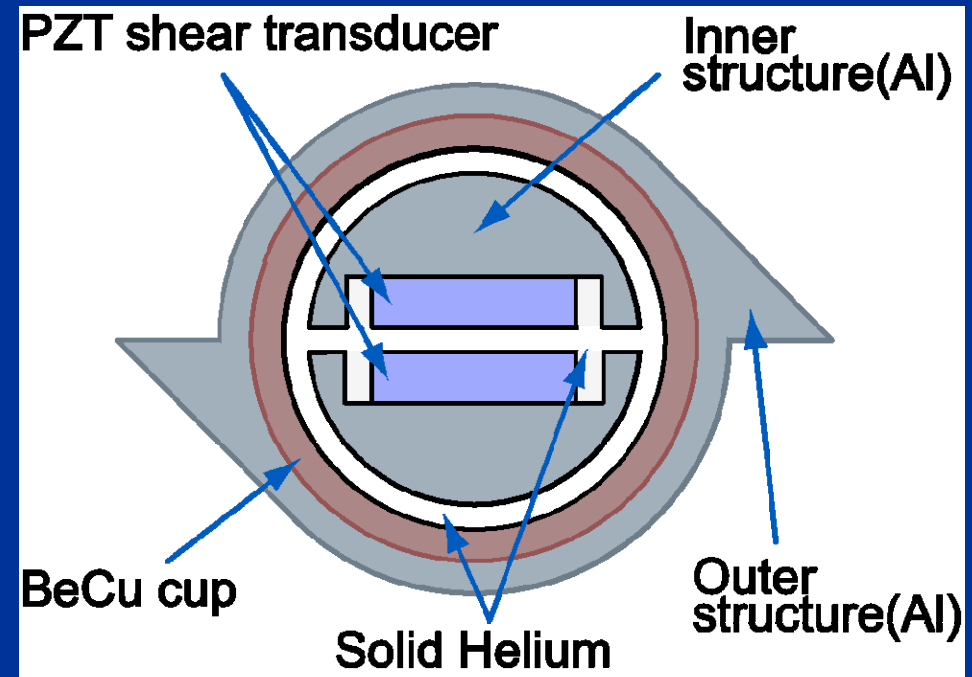

Experiments

- ▶ Sample preparation
 - 10 samples with Blocked capillary method
 - Pressure of samples: 30 ~ 49 bar
- ▶ Same thermodynamic path
- ▶ Same ^3He concentration
- ▶ Compatible S/V ratio

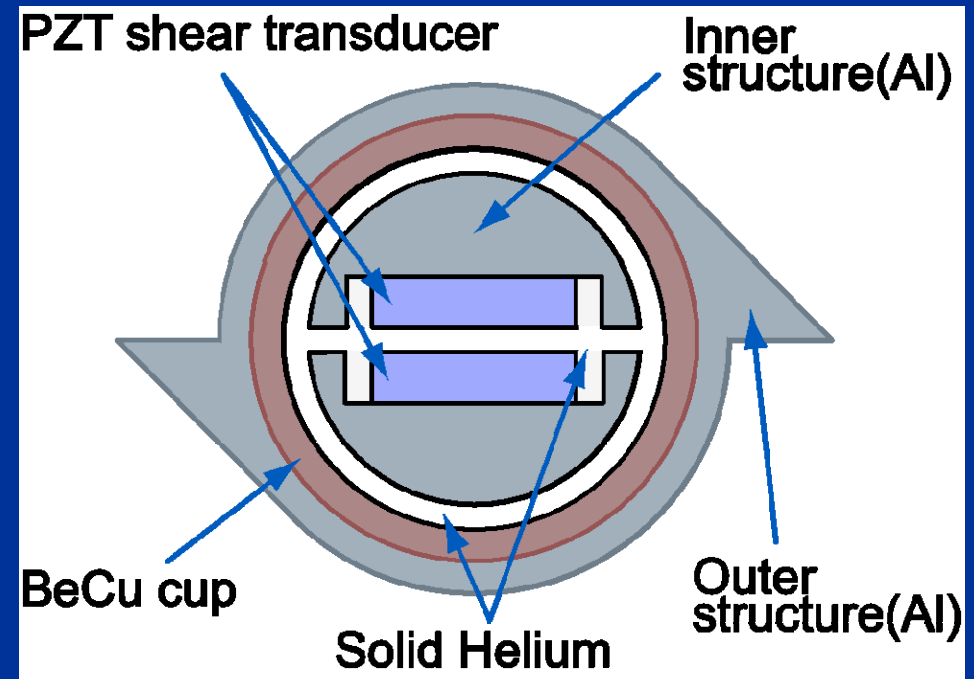
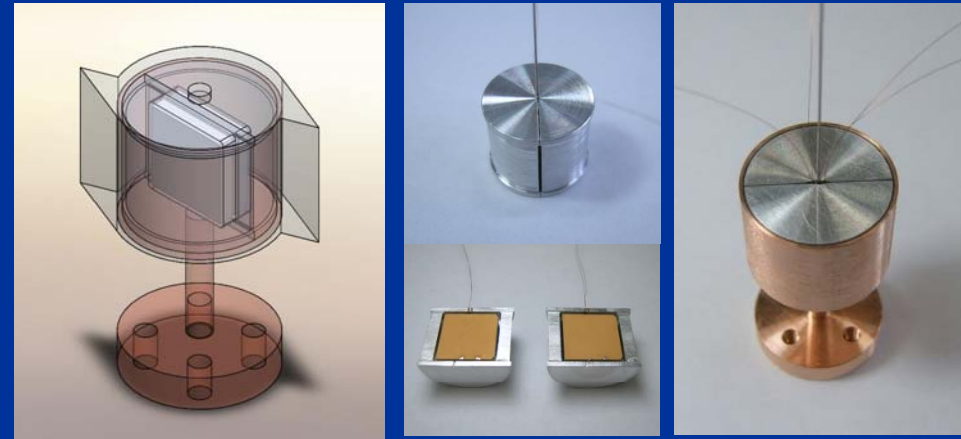

Temperature dependence

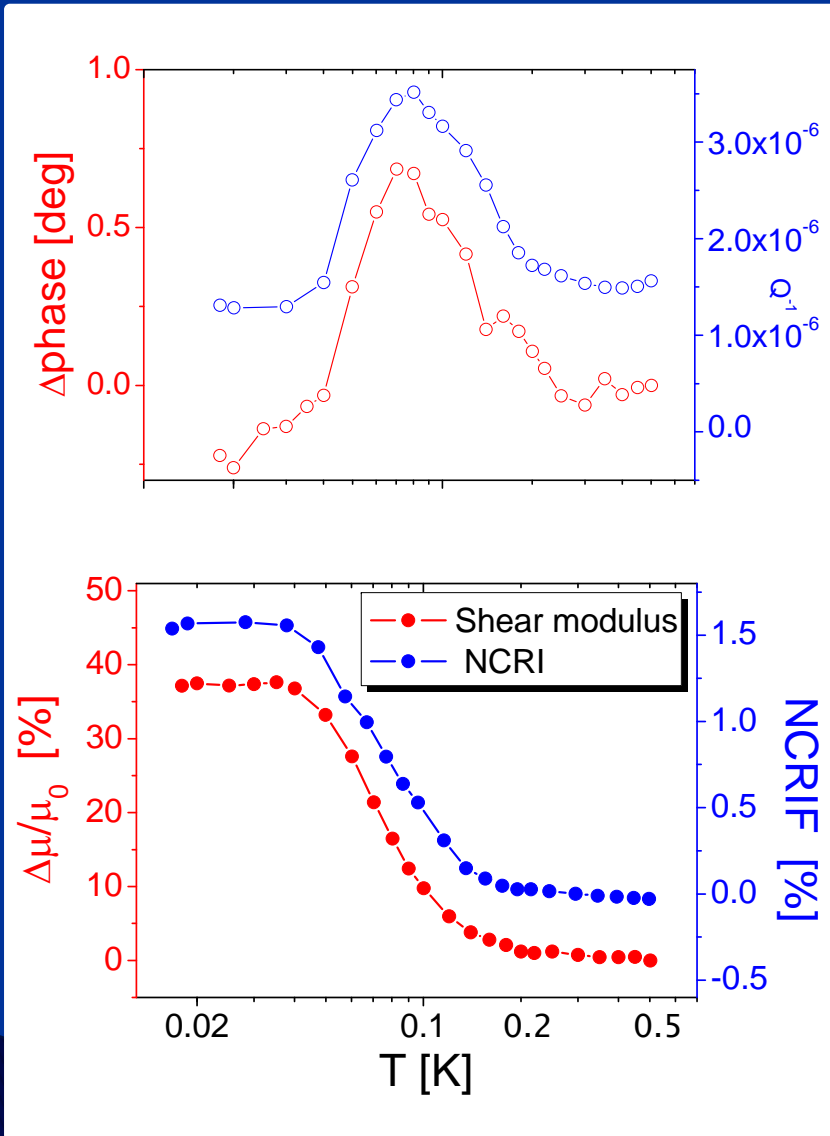

- ▶ **NCRI and the shear modulus increase were observed in a similar temperature range.**

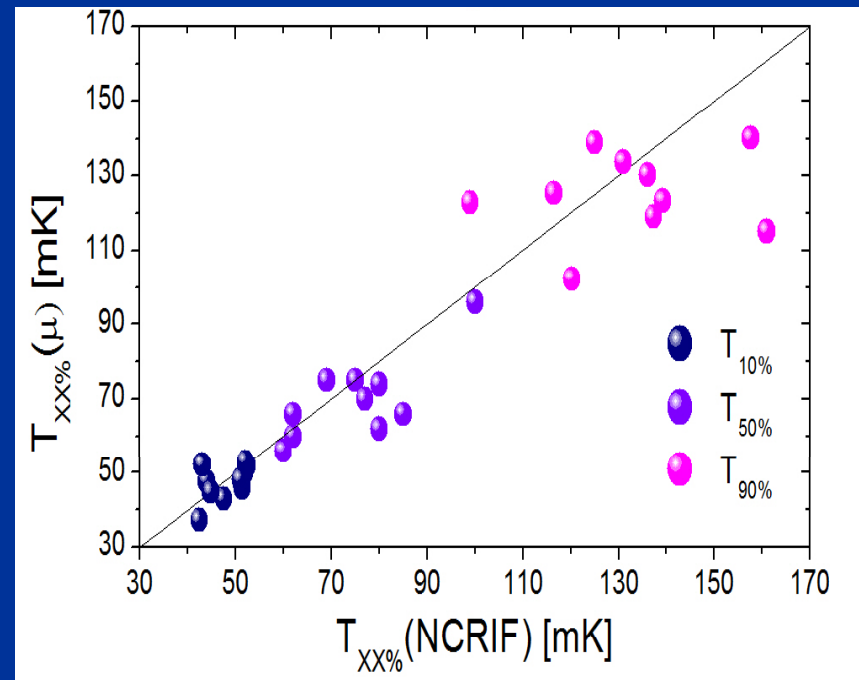

Temperature dependence

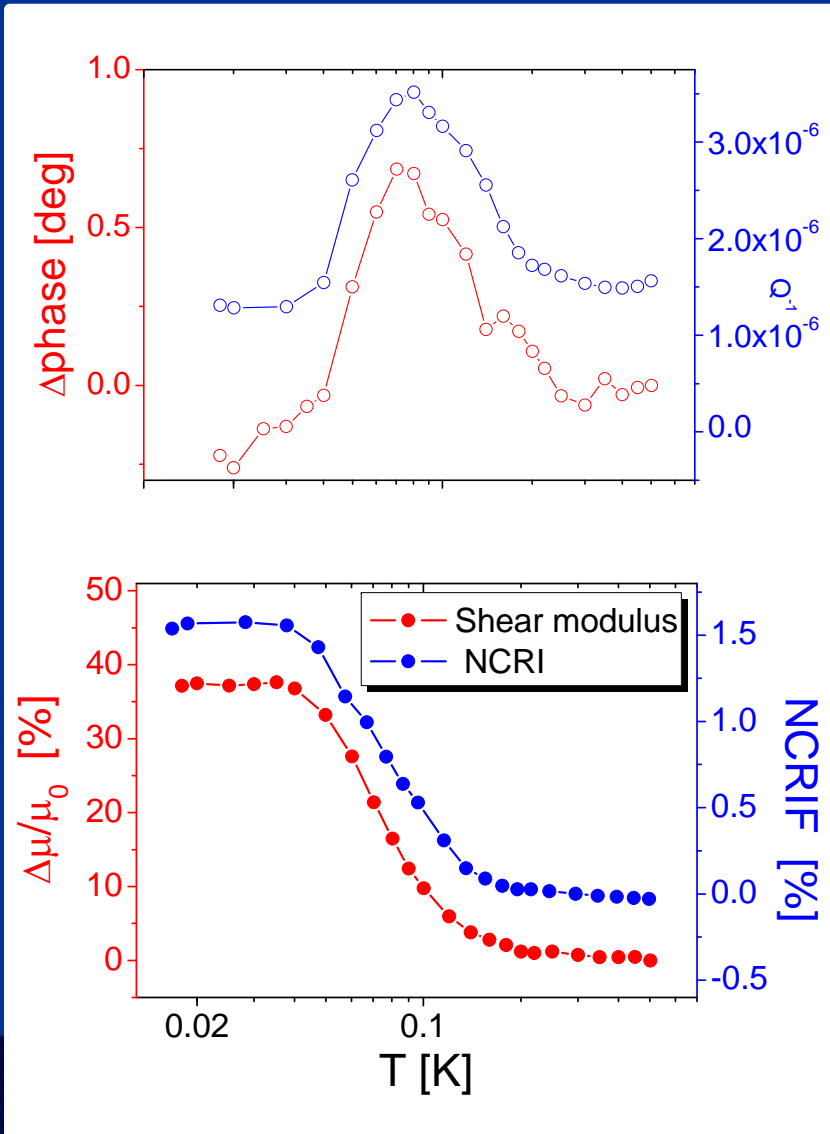

Temperature dependence in shear modulus increase can be understood by ^3He impurity pinning of dislocation network (with broad range of activation energies).

Indeed, characteristic temperature of NCRI traces the pinning temperature of ^3He on dislocation lines.

NCRI probably appears in a stiffened solid!

What is different?

- ▶ No correlation between the magnitude of NCRI and shear modulus change
- ▶ Critical Stress
Supersolidity can be suppressed in a stiffened solid helium.
- ▶ Relaxation
NCRI shows extremely slower relaxation

Simulating the cell with FEM method

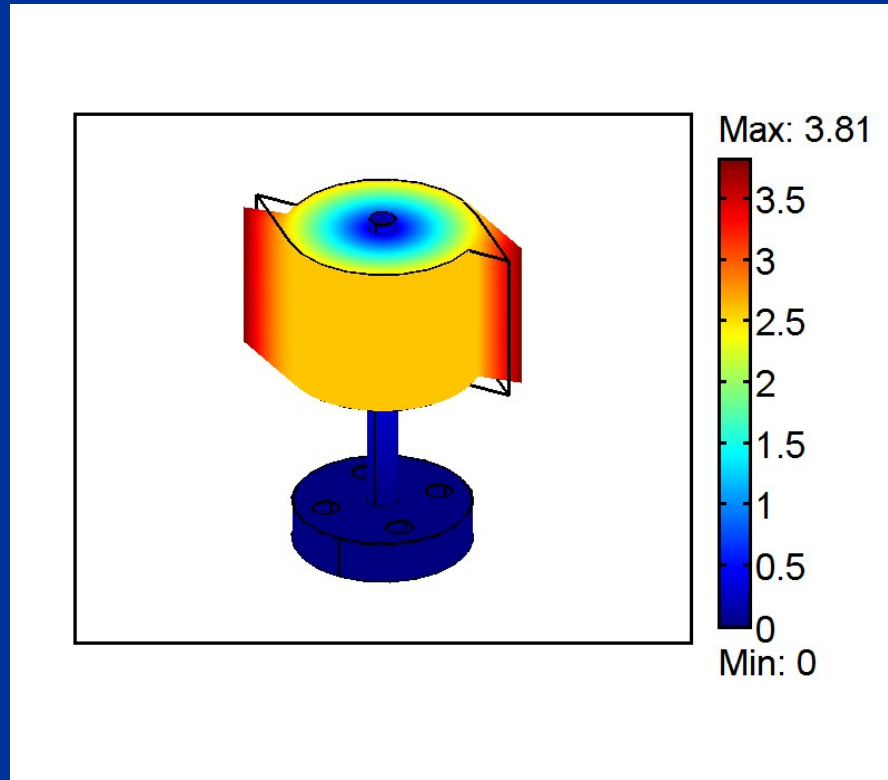

Average NCRIF ~ 2%,
SM increase ~ 25.7%
over 10 samples

$$\frac{df}{f} \approx \left(\frac{d \ln f}{d \ln \mu} \right) \frac{\delta \mu}{\mu}$$

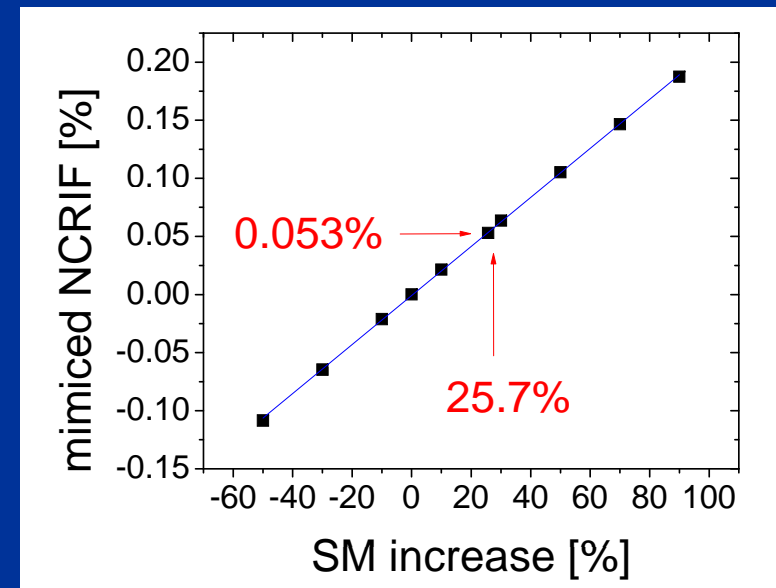

- Eigen frequency analysis

- ✓ Empty cell : 908.88 Hz

- ✓ Solid Helium (SM=1.5x10⁷ Pa)
: 907.06 Hz

No linear relation between NCRI and SM increase

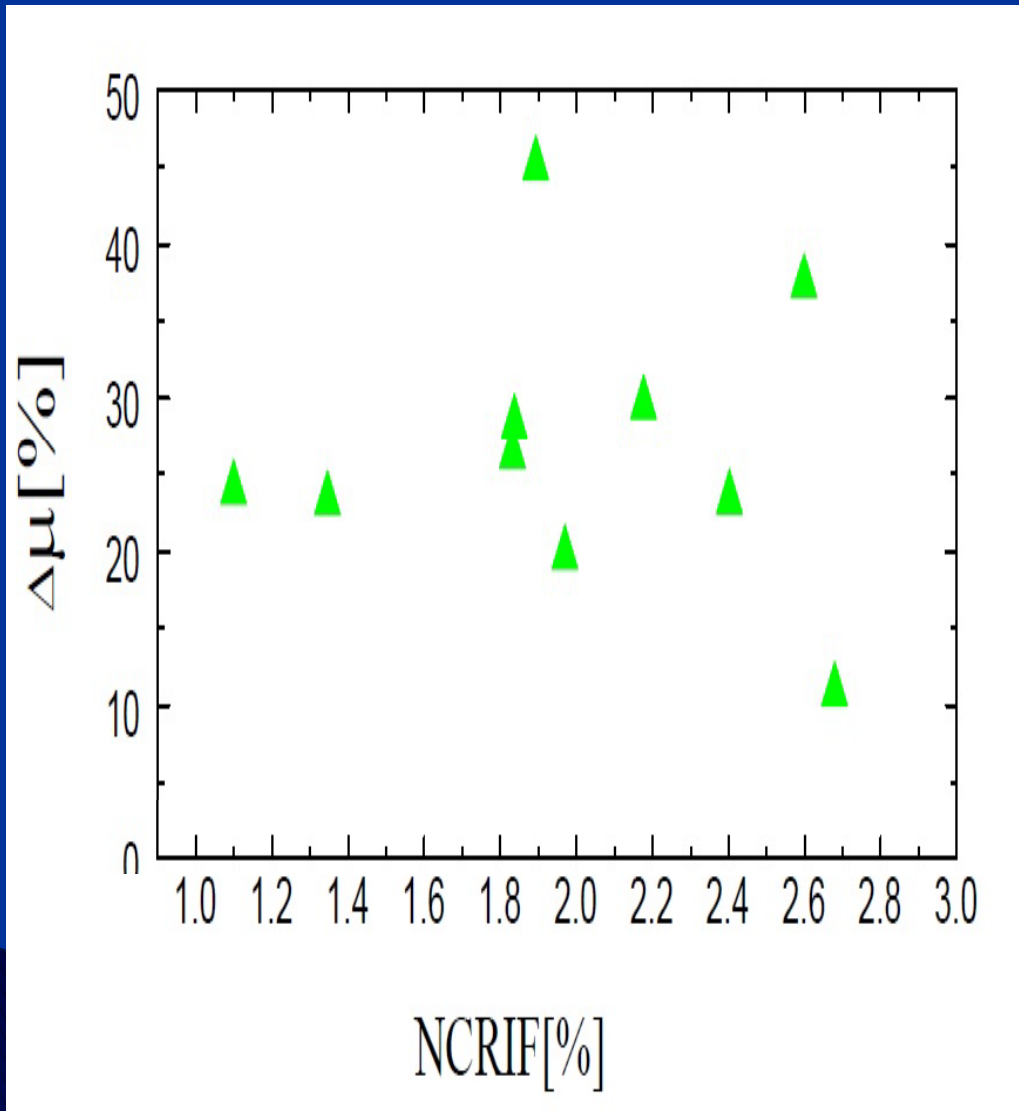

The magnitude of NCRI seems to have a correlation rather with **the absolute value of shear modulus** at low temperatures than the shear modulus increase at low temperatures.

Interference I

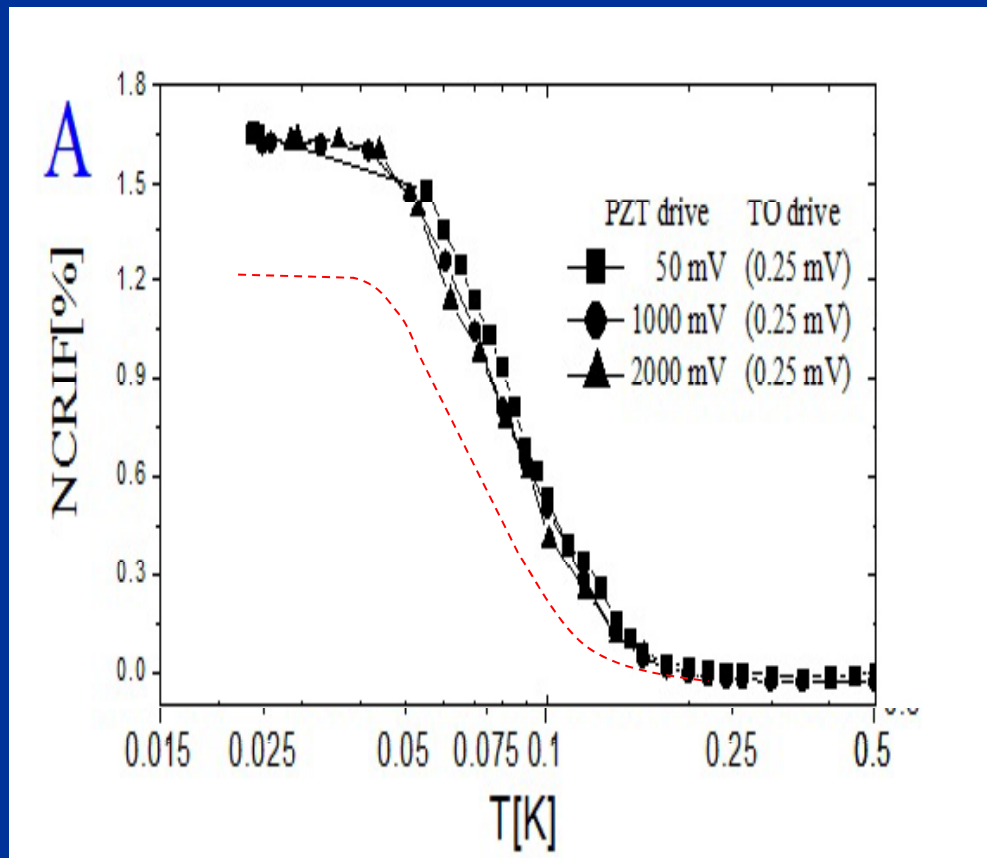

NO interference from **high drive amplitude in PZT.**

The softening of solid helium in the center channel does not affect NCRI

PZT shear transducer

Softened solid

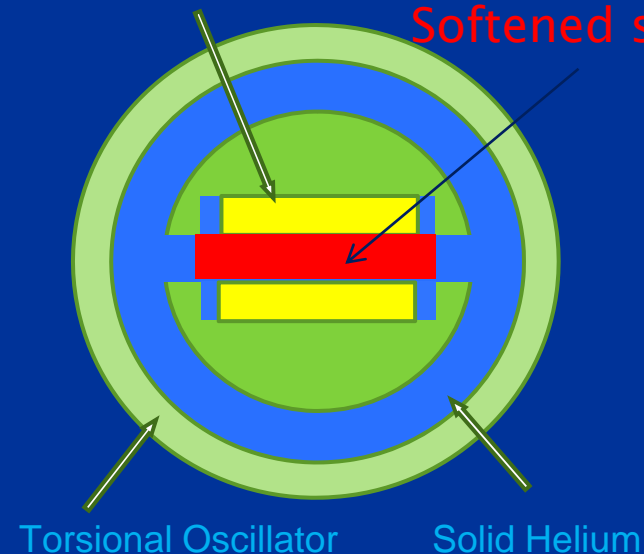

When the reduction in the period is due to SM increase of 25%.

The period shift is expected to be reduced to 1.2%

NCRI and shear modulus change with drive sweep

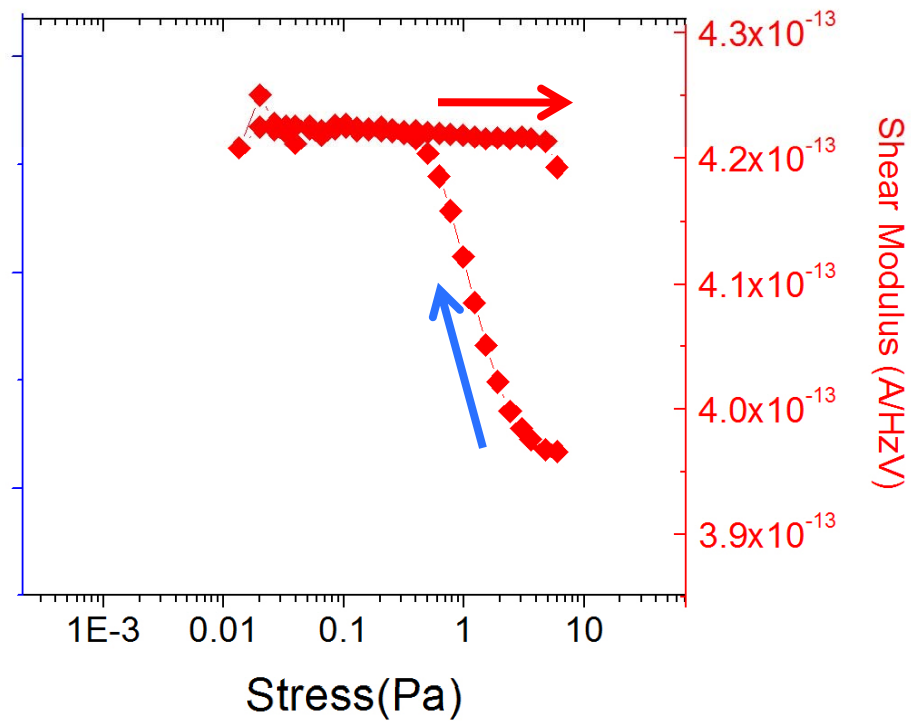

Critical stress of
shear modulus

$$\sigma_c = 0.37 \text{ Pa}$$

Different low temperature excitation destroys NCRI in a stiffened solid helium

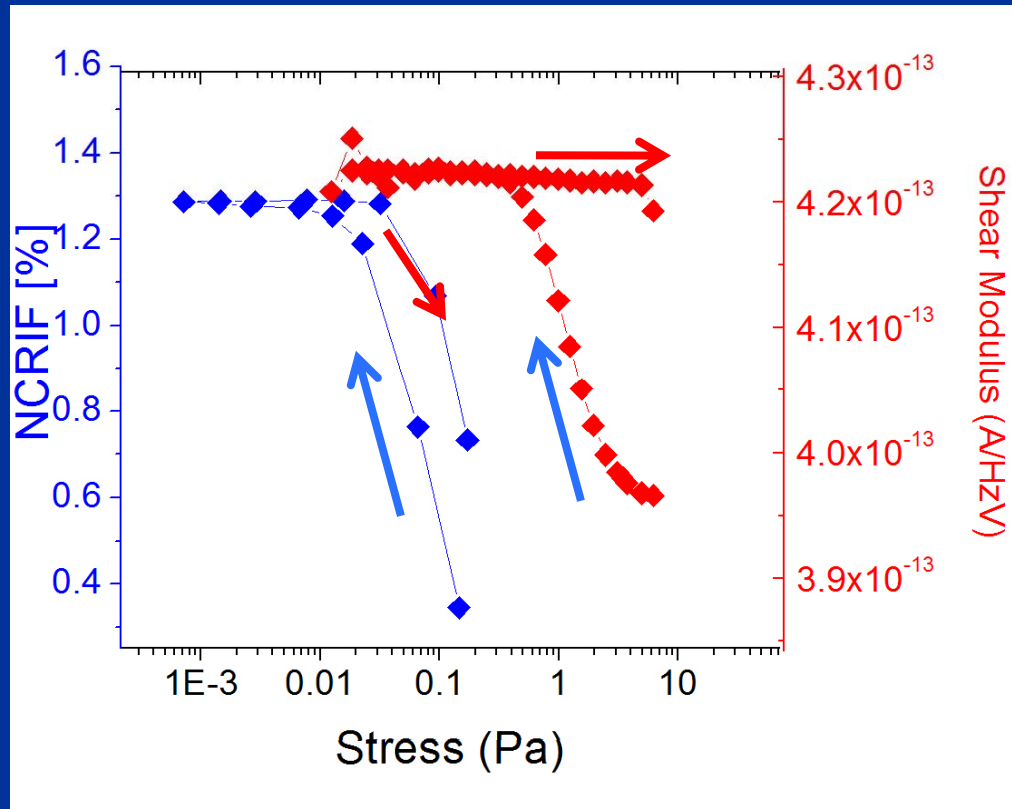

Critical stress of shear modulus

$$\sigma_c = 0.37 \text{ Pa}$$

Critical stress of NCRI

$$\sigma_c = 0.002 \text{ Pa}$$

Stress for solid helium is calculated from the rim velocity of the oscillators. ($\sigma = \rho t \omega v / 2$)

Different low temperature excitation destroys NCRI in a stiffened solid helium

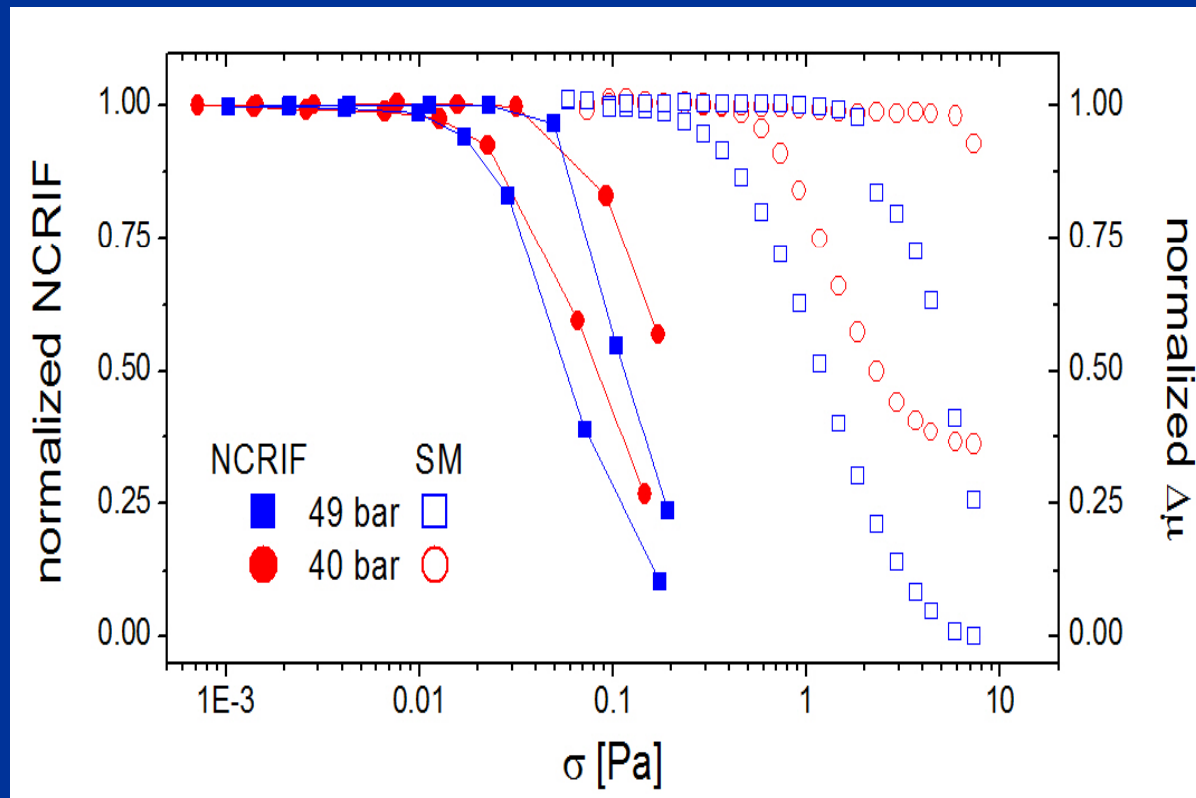

Critical stress for NCRI is always 2 orders of magnitude smaller than that of shear modulus

Interference II

High drive amplitude in TO
→ Any change in the resonant period?

Normal stress on solid helium in the center channel induced by the large torsional oscillations **reduce** the shear modulus.

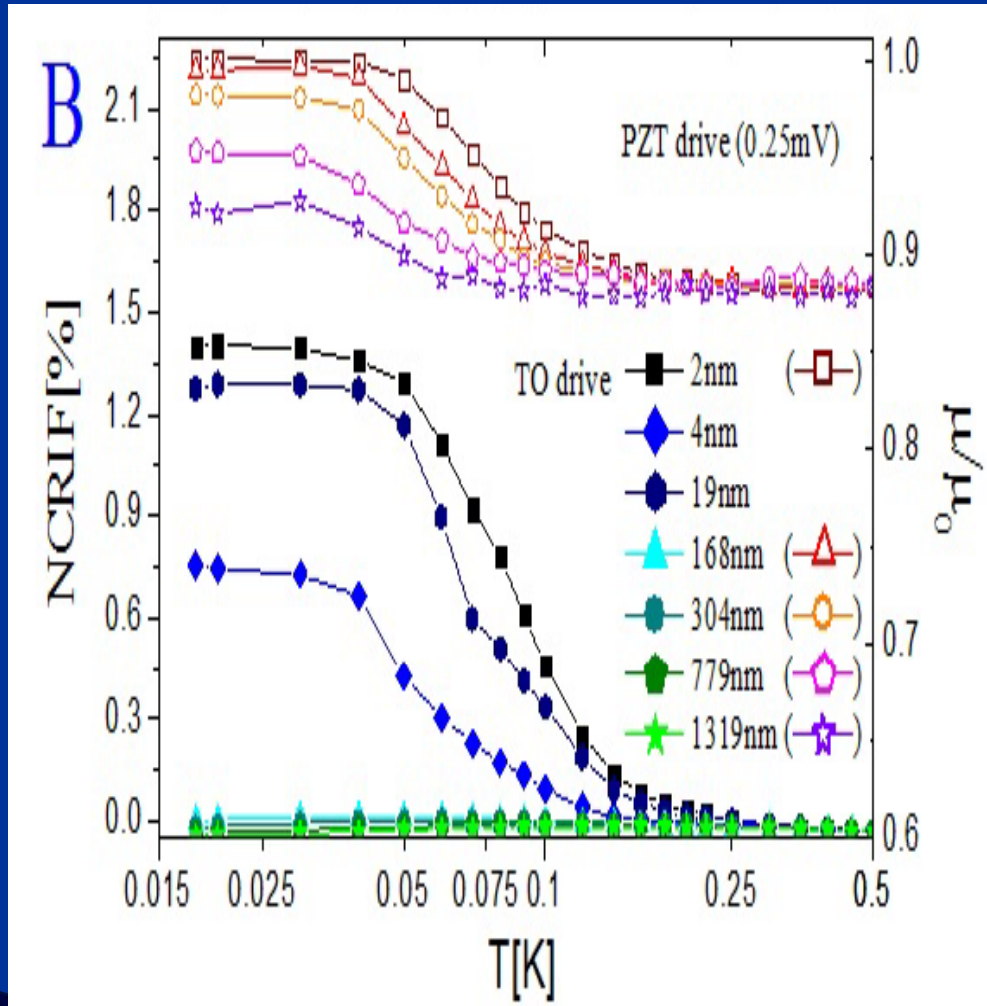

PZT shear transducer

Softened solid

Torsional Oscillator

Solid Helium

Interference II

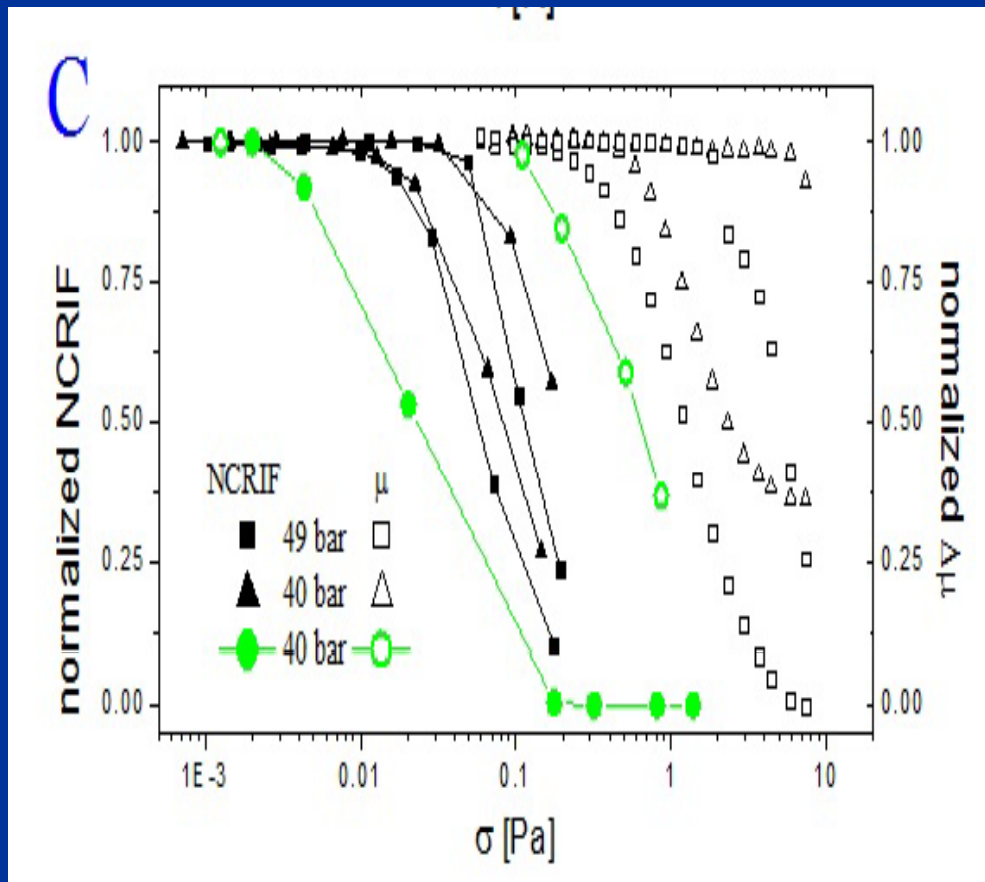

One can estimate the induced stress on solid helium in the center channel by the large amplitude of torsional motion.

The maximum shear stress induced by a normal stress is about $\sigma \sim \rho t w v / 8$.

Again, critical stress for NCRI is always 2 orders of magnitude smaller than that of shear modulus

NCRI shows slower relaxation than shear modulus.

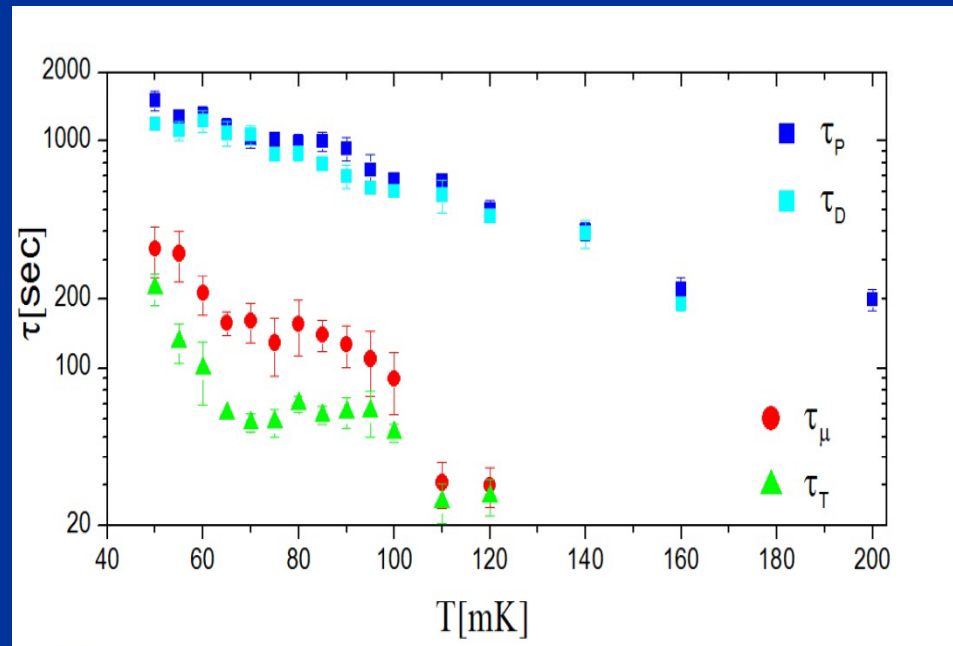
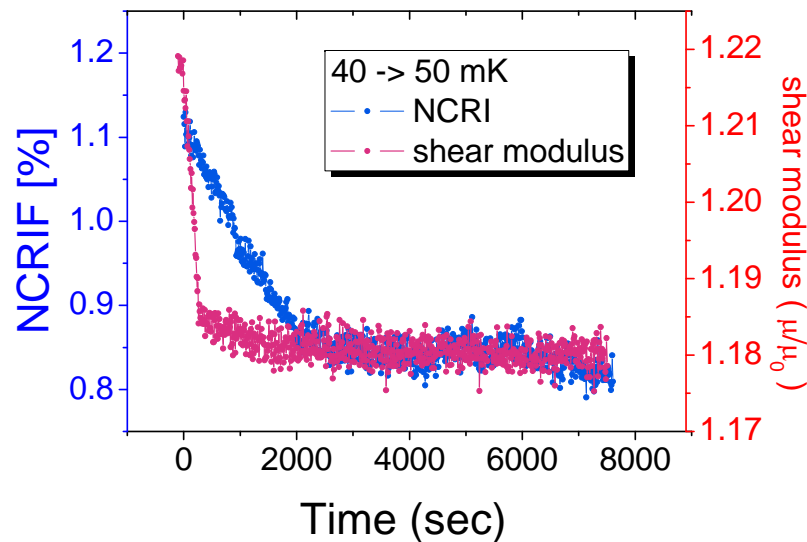
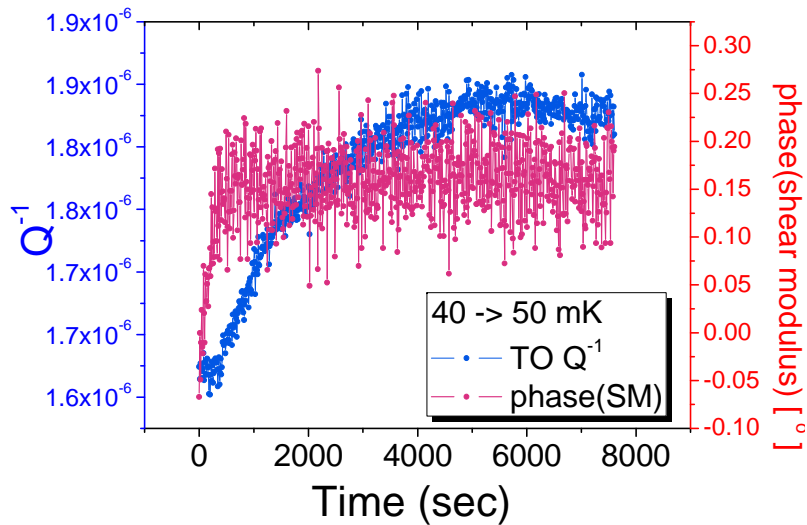

NCRI and shear modulus change by the abrupt temperature increase from 40 mK to 50 mK.

Davidson-Cole plot of the torsional oscillator and SM measurement

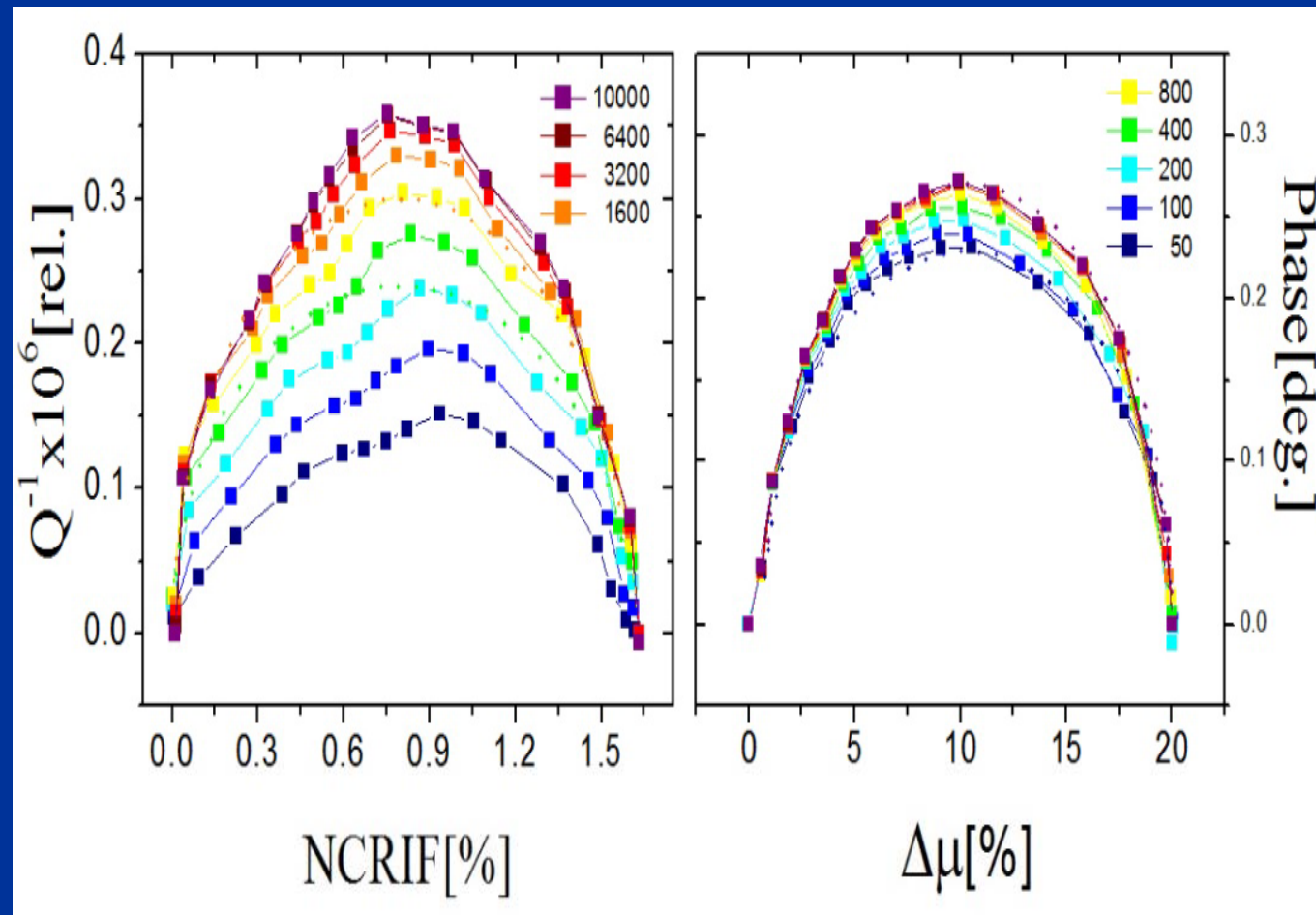

Summary

- ▶ Shear modulus and NCRI are measured simultaneously.
- ▶ NCRI and SM in solid helium are closely related but not exactly same effect.
- ▶ NCRI has lower critical stress than the SM increase.
- ▶ NCRI shows slower relaxation at low temperatures.
- ▶ Another low temperature excitation in NCRI should exist.

LT group at KAIST

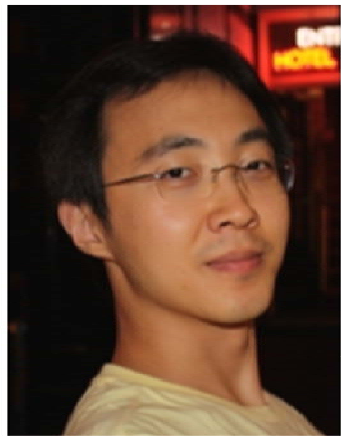

D.Y. Kim



S. Kwon

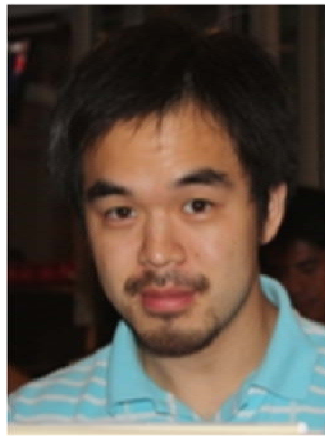

H. Choi

